

# Five Key Elements

# 1

## Bridge Structure

It is an acknowledged fact that no serious high speed milling can be accomplished on a conventional C-frame vertical machining center.

VIBRA-FREE HD is different. Its second-generation unique bridge structure eliminates overhang. Its optimal weight distribution allows rapid travel and response. Its full-stroke supported, no-sag table can machine blocks up to 45 by 24 inches weighing up to 2000 pounds. Thermally controlled ball-screws and special Schneberger™ roller guide-ways eliminate stiction. Way guard protection extends end to end and its 20-station tool-changer is protected from tool steel, composites or graphite.



### C-Frame VMC

- 1 Table overhangs and offsets from Y-axis at the end of X stroke.
- 2 Long distance between spindle centerline and its supporting and driving mechanism.

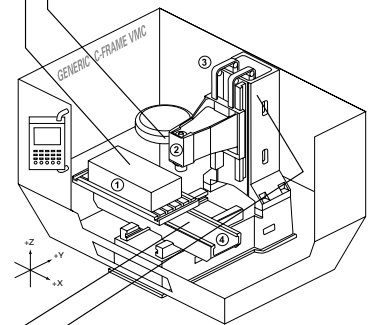

- 3 Heavy Z head requires counterweight or slows Z motion.
- 4 More weight is allotted to moving structure, limiting machine's dynamic response – the essence of High-Speed Machining.

# 2

## Integral Spindle

Made to perform under extreme conditions, VIBRA-FREE HD's 24,000 rpm (optional 30,000 rpm) spindle with intelligent cooling and monitored mist lubrication keeps thermal growth in check from one shift to the next, spinning at maximum speed.



HSK 63 pre-balanced, double-face-contact tooling accepts extended tool holders with the rigidity to machine deep cavities. Roughing is no longer a problem with a 40 continuous horsepower spindle offering full torque at 50 RPM. When the

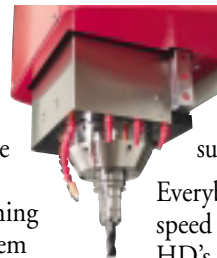

roughing is done, keep your part on the VIBRA-FREE HD and finish it. At 30,000 rpm, brilliant surface finish is our trademark.

Everybody worries about high-speed spindles. VIBRA-FREE HD's spindle longevity is backed by local response and repair/exchange policies that don't kill the pocketbook.

# 3

## Controlling Thermal Growth at the Source



The challenge of high speed machining is controlling thermal expansion at high feeds and speeds. Thermal growth results in poorer finishes, poorer tolerances and hours of baby-sitting. VIBRA-FREE HD handles heat growth from the ground up. Symmetric bridge construction minimizes distortion despite changes in ambient temperature. An independently controlled spindle chiller and a separate ball-screw chiller extract heat from the source.



On-demand, intelligent lubrication systems are built into the VIBRA-FREE

HD. Your maintenance technicians can relax and leave the worrying to the VIBRA-FREE HD, running 24/7.