

Tool Steel P20 Work Sample

Machine

VIBRA-FREE super high-speed machine center

- Cutting feed-rate 472 in/min
- Advanced FANUC 16i-MA CNC with High Precision Contour Control (HPCC)
- Direct drive (motorized) Super-High-Speed spindle (42000RPM)
- Vibration-free rigid NT bridge structure
- Compact ATC with 18 tools
- Graphite & direct hard milling (Up to HRC60) capability

Part (Blank size: 5" x 3" x 1")

Connecting rod forging die

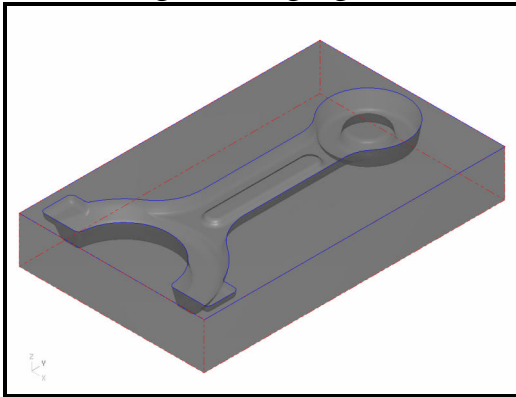

Specifications

Number of program: 2 (O0105, O0116)

Number of cutting tool: 1 (T15)

Stock materials: P20 (HRC35)

Demo Summary

TOOLPATH	CUTTER	COATING	RPM	IPM	TIME (min)
Rough	3mm Ball EM	TIALN	31000	157	25.0
Finish			31000	197	12.5
Total time					37.5